

Regions of the plane: relationships between variables

Exercise. $y = x^4$, $y = x^{1/3}$ enclose a region R of the plane.

- Find the area of R.
- Form a solid by rotating R around the axis $y=2$. Find its volume.
- Form a solid by rotating R around the axis $x=-1/2$. Find its volume.

Do we really care about answering such artificial questions? Of course not. This is practice in understanding relationships between variables which is important in some real calculus applications.

Intersection pts

$$x^4 = x^{1/3}$$

$$(x^4)^3 = (x^{1/3})^3$$

$$x^{12} = x$$

$$x^{12} - x = 0$$

$$x(x^{11} - 1) = 0$$

$$\downarrow \quad \downarrow$$

$$x=0, \quad x=1$$

$$\downarrow \quad \downarrow$$

$$y=0 \quad y=1$$

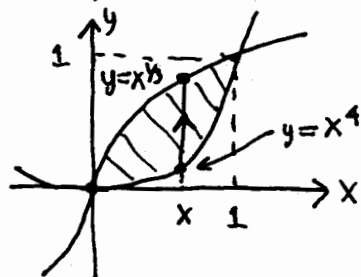

"for each x from 0 to 1, y goes from x^4 to $x^{1/3}$ "

OR CHANGE OF INDEPENDENT VARIABLE:

$$y = x^{1/3} \rightarrow y^3 = (x^{1/3})^3 = x \rightarrow x = y^3$$

$$y = x^4 \rightarrow y^{1/4} = (x^4)^{1/4} = |x| = x \rightarrow x = y^{1/4}$$

$x > 0$ here.

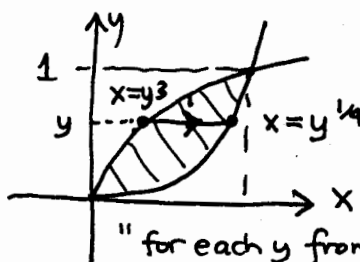

"for each y from 0 to 1, x goes from y^3 to $y^{1/4}$ "

a) x-approach: $L(x) = x^{1/3} - x$ (upper-lower)

$$A = \int_0^1 L(x) dx = \int_0^1 x^{1/3} - x dx$$

y-approach: $L(y) = y^{1/4} - y^3$ (right-left)

$$A = \int_0^1 L(y) dy = \int_0^1 y^{1/4} - y^3 dy$$

b)

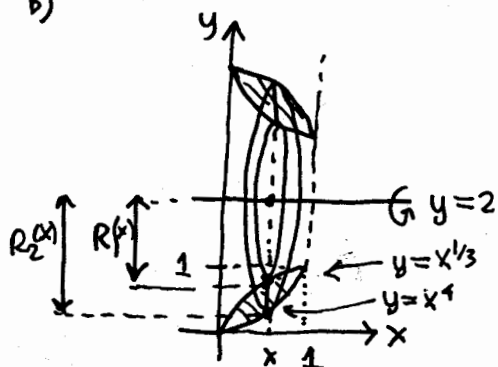

$$A(x) = \pi R_2(x)^2 - \pi R_1(x)^2 = \pi (R_2(x)^2 - R_1(x)^2)$$

$$V = \int_0^1 A(x) dx = \int_0^1 \pi ((2-x^{1/3})^2 - (2-x^4)^2) dx$$

$$R_1 = 2 - x^{1/3}$$

$$R_2 = 2 - x^4$$

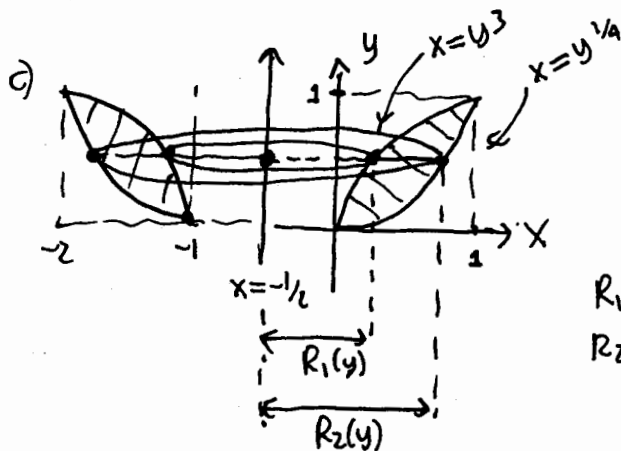

$$A(y) = \pi (R_2(y)^2 - \pi R_1(y)^2 = \pi (R_2(y)^2 - R_1(y)^2)$$

$$V = \int_0^1 A(y) dy = \int_0^1 \pi ((y^{1/4} + 1/2)^2 - (y^3 + 1/2)^2) dy$$

$$R_1(y) = y^3 - (-1/2) = y^3 + 1/2$$

$$R_2(y) = y^{1/4} - (-1/2) = y^{1/4} + 1/2$$